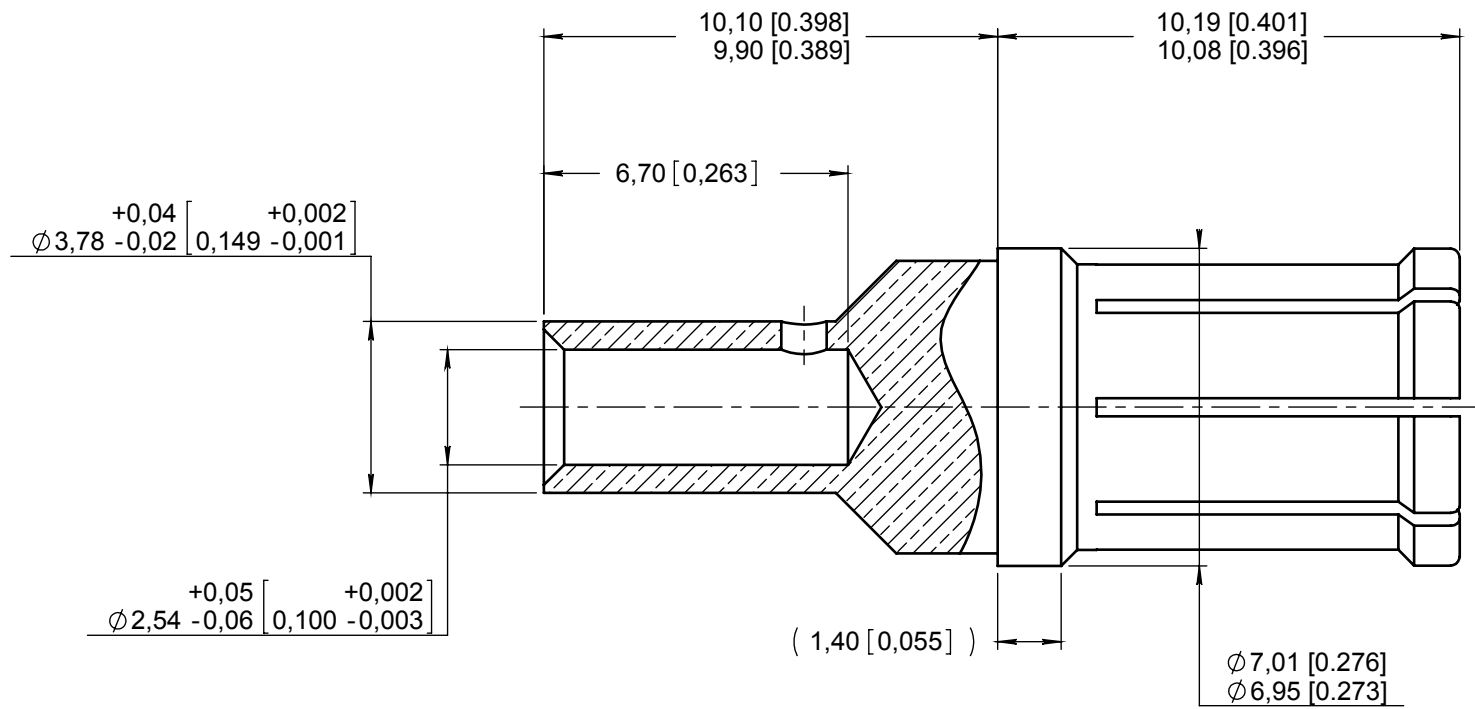
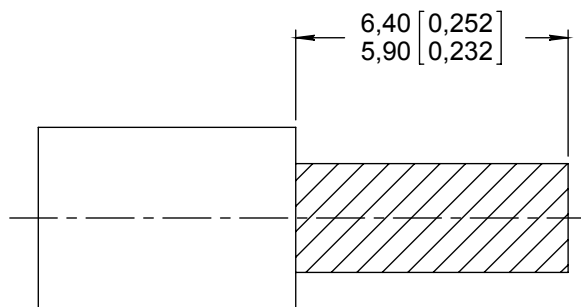

Series
EPX
Size 5 power socket contact
For AWG 12, AWG 14 and AWG 16 cables.
Issue:
Jul. 13, 2018
Page
1/1

WIRING INSTRUCTIONS :

- Cable stripped length

MATERIAL AND FINISH :

- Copper alloy, gold over nickel

EXTRACTION TOOL :

 - FOR AWG 16, AWG 14 & AWG 12 : M81969/28-01
 Radiall P/N 282946

CRIMPING TOOL :

- FOR AWG 16; AWG 14 & AWG 12 : Radiall P/N 282 613

POSITIONER :

- FOR AWG 16; AWG 14 & AWG 12 : Radiall P/N 282 586 005

SELECTOR SETTING :

 - FOR AWG 16 : 4
 - FOR AWG 14 : 5
 - FOR AWG 12 : 6

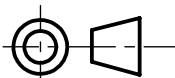
DIMENSIONS : mm (inch are given for information only)

Estimated weight : 2.5 g

CREATION
PEN:
NOM: L.Garcia

DATE: Jan. 22, 07

APPR.: M.Pessard

| Issue | Revisions | Name | Approved |
|--------------|---|----------|-----------|
| Jul. 13, 18 | Correction in dimension 6,7 [0,263] Added parentheses to dimension 1,4 [0,055] | Lopez C. | Weihls H. |
| Sept 08, 14 | Added AWG 14 wires and weight updated | SURAUULT | Vieira |
| April 24, 13 | Added AWG 16 wires | Vieira | Legloahec |

617370001EN

RADIALL PROPRIETARY INFORMATION

This document contains proprietary information and such information shall not be disclosed to any third party for any purpose whatsoever or used for manufacturing purposes without prior written agreement from RADIALL. This information is given as an indication. In the continual goal to improve our products, we reserve the right to make any modifications judged necessary.

4112_9311